

6 PANEL MERKEZİ KABİN KAPISI - 2 KAŞIK

6 PANEL CENTRAL CAR DOOR - 2 SKATE



TEKNİK ÖZELLİKLER

- » ÜRETİMDEKİ KAPI ARALIĞI : 1600MM & 3000MM
- » Değişik motor ve sürücüler ile farklı kullanım olanakları sunar
- » Kompakt yapısı sayesinde montaj kolaylığı sağlar
- » Orta ve yoğun trafikli binalar için seçim sağlar
- » Ağır hizmet kaplarına göre programlanma özelliği
- » Brushless motor sürme özelliği sayesinde trafiği yoğun ve yüksek hızlı asansörlerde 1 m/s hızda aranan en iyi çözümü sunar
- » Düşük enerji tüketimi

PRLO6

M06 / C / SERİ 14

TECHNICAL SPECIFICATIONS

- » DOOR PRODUCTION CAPACITY : 1600MM & 3000MM
- » Different uses with different engines and drives offers opportunities and ease of assembly
- » Provides choice for medium and heavy traffic buildings
- » Ability to work independently from the load programmable feature according to the heavy-duty doors
- » Brushless motor drive feature offers the heavy traffic and high-speed elevators, 1 m/s speed on demand offers the best solution
- » Low energy consumption

1600 mm'den 3000 mm'ye
kadar standart üretim

From 1600m to 3000 mm,
standart production

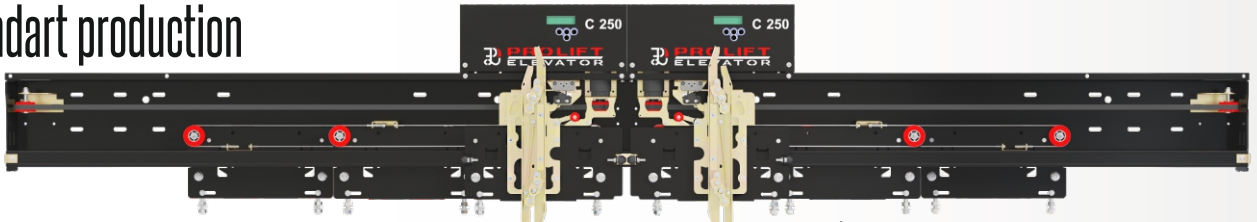

6 PANEL MERKEZİ KABİN KAPISI - 2 KAŞIK

6 PANEL CENTRAL CAR DOOR - 2 SKATE

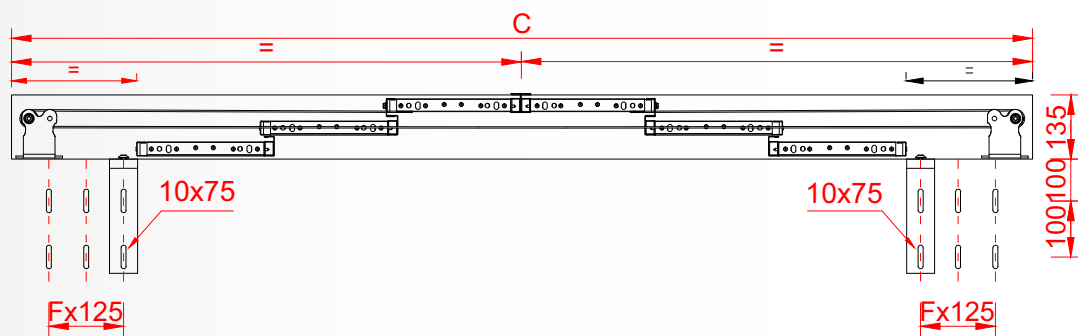
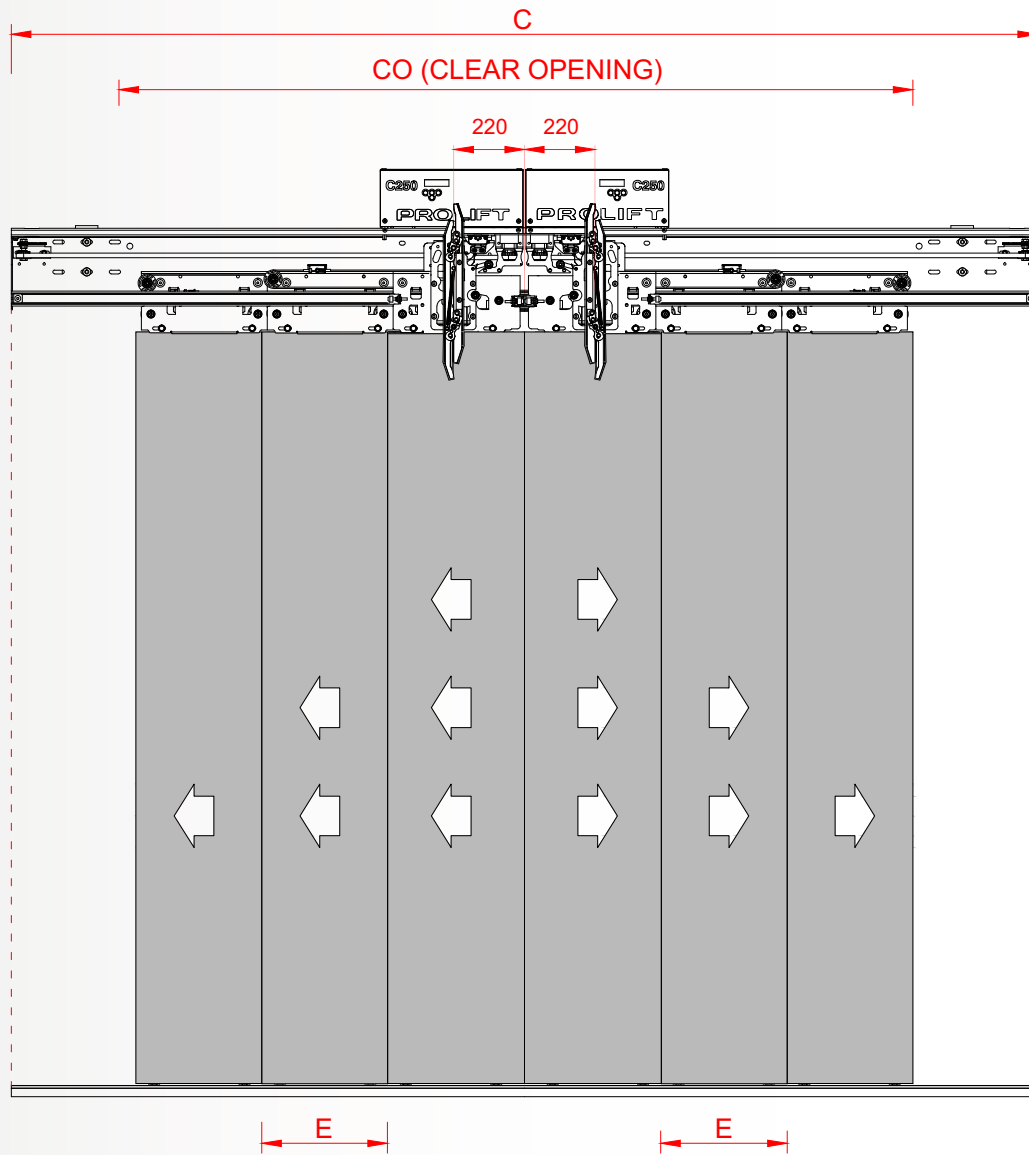

CO	1600	1700	1800	1900	2000	2100	2200	2300	2400	2500	2600	2700	2800	2900	3000
C	2190	2330	2460	2590	2730	2860	2990	3130	3260	3390	3530	3660	3790	3930	4060
E	295	315	330	345	365	380	395	415	430	445	465	480	495	515	530

6 PANEL MERKEZİ KABİN KAPISI - 2 KAŞIK ÖLÇÜLERİ

6 PANEL CENTRAL CAR DOOR - 2 SKATE DIMENSIONS

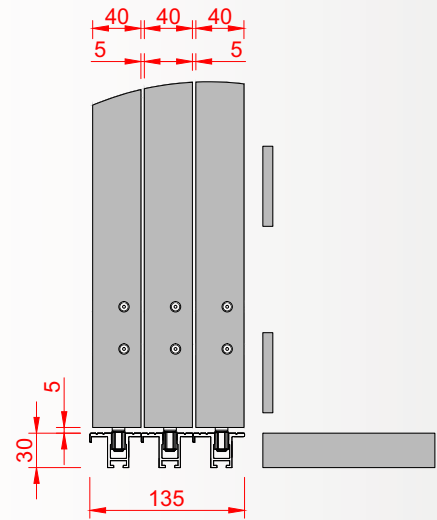
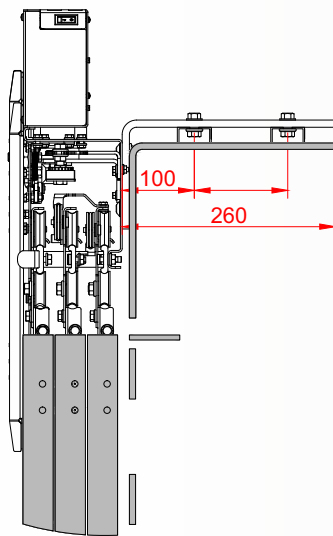
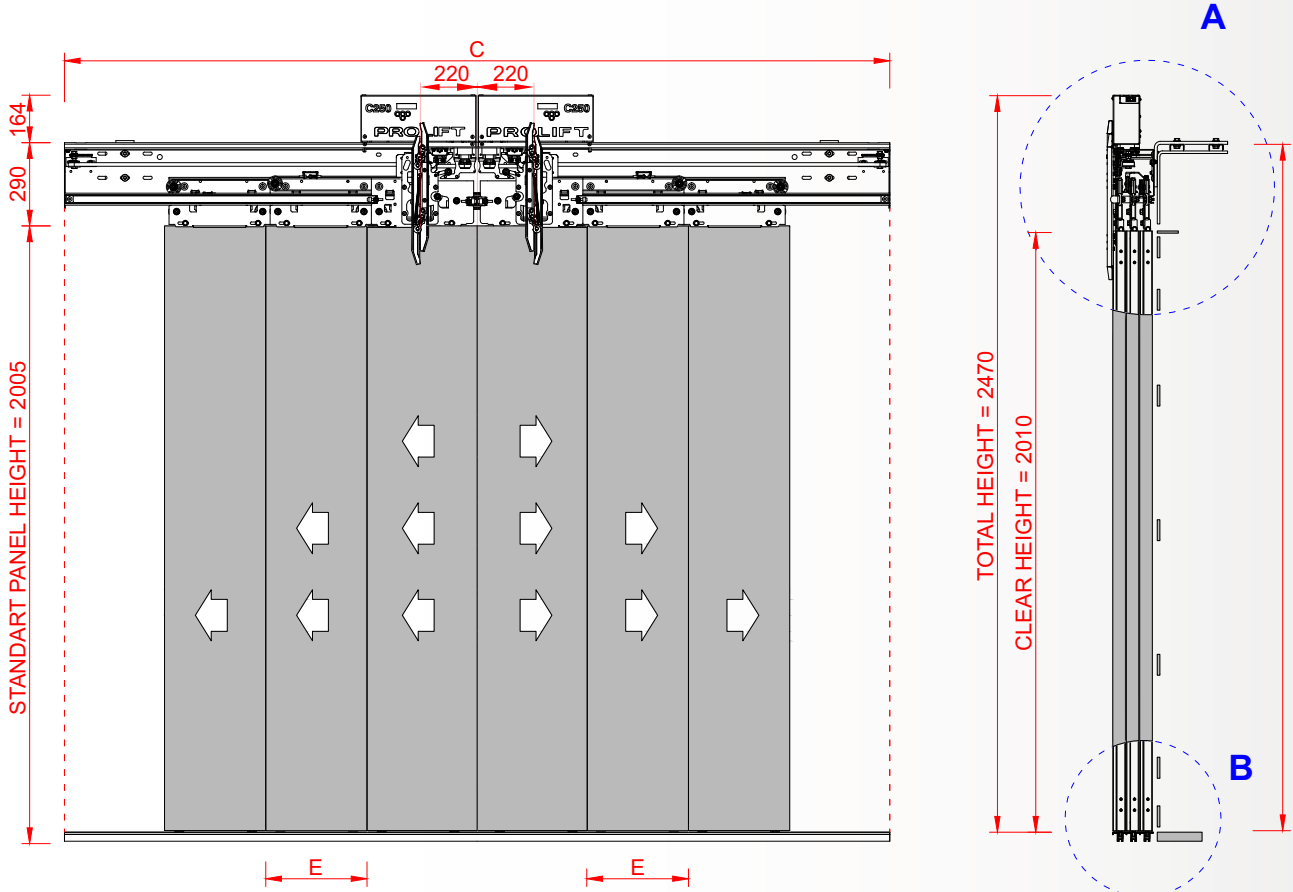

6 PANEL MERKEZİ KABİN KAPISI - 2 KAŞIK KAŞIK VE KİLİT

6 PANEL CENTRAL CAR DOOR - 2 SKATE SKATE AND LOCK ARRANGEMENT

